

TS-285
 Rev. E
 P.D. Oscillating Piston
 Flowmeter:
 25.4mm (1") RL100

Itron

neptune

**L.P. GAS FLOWMETER
 1" TYPE 4D-MD
 ALUMINUM BODY
 DISPENSER METER**

SPECIFICATIONS

DESCRIPTION

The Itron 1" Type 4D-MD meter, with double case design, has been specifically designed for the custody transfer of liquified propane and butane gas (LPG). This meter utilizes the oscillating piston positive displacement measuring chamber technology. The 1" Type 4D-MD is particularly suited for filling portable gas bottled and fuel containers for portable burners, pavement heaters, weed burners, fork lift trucks and motor fuel tanks.

The standard unit includes the base meter with the choice of either a 600 Series totalizing register with a resettable counter or an 800 Series printer register. A differential control valve, combination vapor eliminator/strainer, continuous bleed pressure relief valve and tubing kit are also included. An optional automatic temperature compensator (ATC) is available. The ATC senses product temperature and adjusts the readout to result in registration that is compensated to 15°C (60°F).

DESIGN FEATURES SUPERIOR ACCURACY

The Neptune designed oscillating piston measuring chamber is both accurate and reliable. The piston is treated with a special coating which protects it from damage by impurities and adds lubricity for smooth performance at low flow and high operating pressures.

FLEXIBILITY

Rugged outer body components in a compact design make the 1" Type 4D-MD useable in a wide variety of installation configurations. The meter is also available with several different register options, and in temperature compensated and uncompensated versions.

UNITS OF MEASURE

Neptune 600 and 800 Series registers offer a full range of options for calibration in U.S. gallons, Litres and Imperial gallons, with 5 digit reset and an 8 digit non-resettable totalizer.



1" 4D-MD with 600 Series Register

OPERATING SPECIFICATIONS

Flow Rate	LPM	US Gal./Min.
Maximum	68	18
Minimum	11	3
Operating Pressure	Bars	PSI
Maximum	24	350
Minimum	See Note	
Operating Temperature (without ATC)	°C	°F
Maximum	60	140
Minimum	-23	-10
Temperature Compensation (ATC)		
Compensates to a basepoint of 15°C (60°F)		
Range: -23°C to 52°C (-10°F to 125°F)		
Connections		
Ductile iron companion flange tapped for 3/4" std. pipe		
Optional ductile iron companion flange tapped for 1" std. pipe		

Note: A minimum of 1.034 bars (15 psi) is needed to open the differential control valve, plus pressure loss in the system.

DIMENSIONAL DATA, mm (in.)

**1" 4D-MD with
800 Series Register**

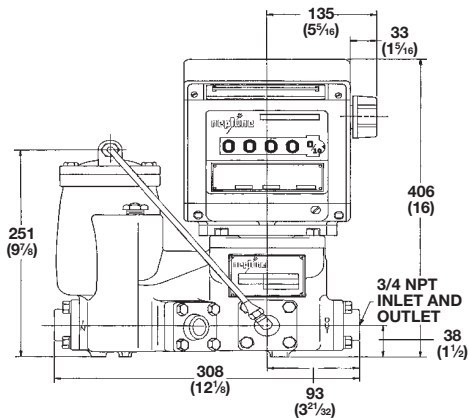

**1" 4D-MD with
600 Series Register**

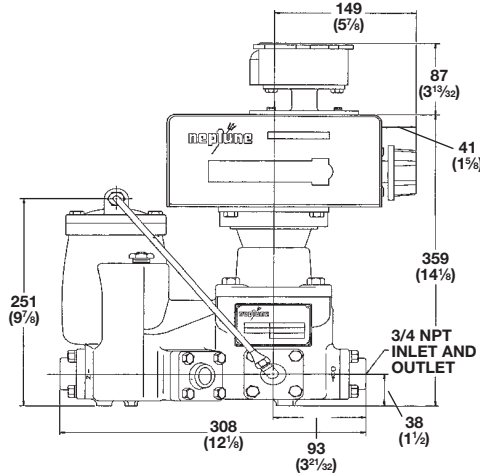

**1" 4D-MD with
600 Series Register and ATC**

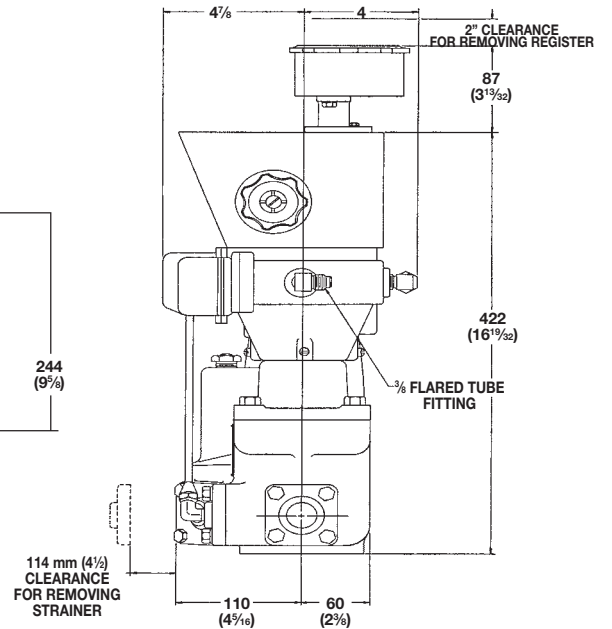
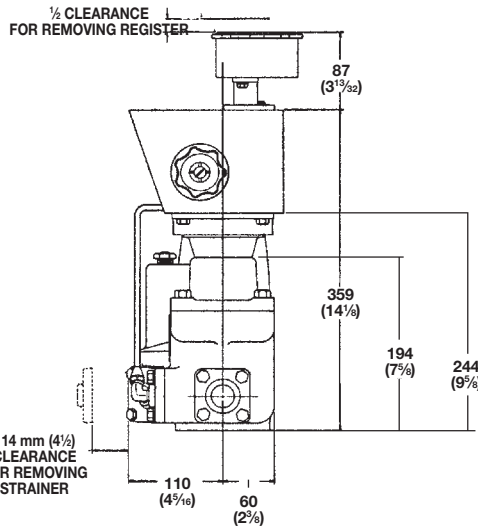
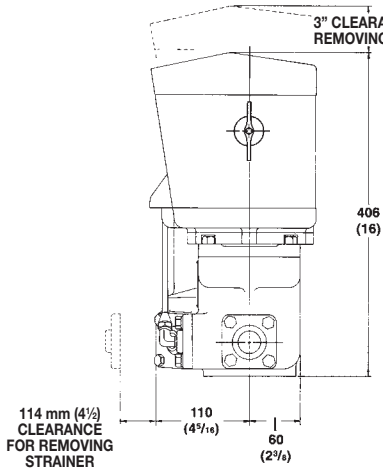
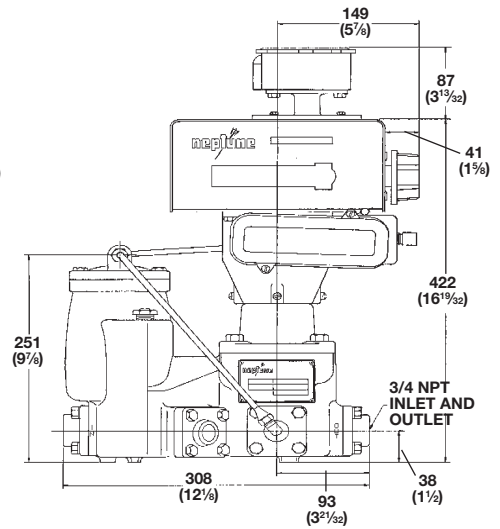

**Bottom View
All Configurations**

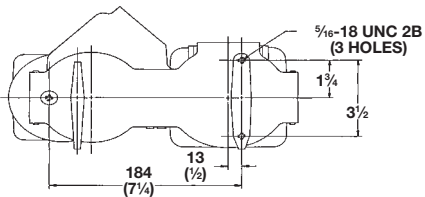

Specify Genuine Neptune Replacement Parts

Accuracy of all Neptune Type 4D Custody Transfer Meters for use with L.P. Gas and Butane meets or exceeds N.I.S.T. Handbook 44 Parameters.

U.S.A./International
1310 Emerald Road
Greenwood, SC 29646-9558
Tel.: Toll-Free (800) 833-3357
(864) 223-1212
Fax: (864) 223-0341

© 2009 Itron, Inc. 500 12/09

Specifications subject to change without prior notification.

